

STRUT MOUNTING PLATES

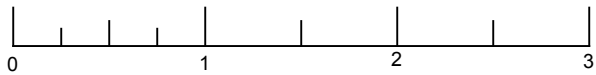

SCALING

PRINT AT 100%. BOUNDING BOX MEASURES 7.5 X 10 INCHES. FRONT AND REAR FLOAT PIECES ARE EACH 9 INCHES LONG.

POCKET FOR WHEELS

FRONT

REAR

FRONT SPREADER
.032 MUSIC WIRE

REAR FLOAT STRUT
.040 MUSIC WIRE

REAR SPREADER
.032 MUSIC WIRE

DETAIL VIEWS NOT TO SCALE

- A - PROP ARC
- B - FRONT STRUT MOUNTS
- C - WHEEL POCKET
- D - CG OF MODEL
- E - REAR STRUT PLATE

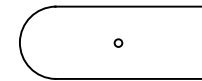

FRONT, 2X

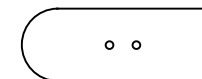

REAR, 2X

STRUT MOUNTING PLATES CUT FROM POPSICLE STICKS OR 1/32 PLY

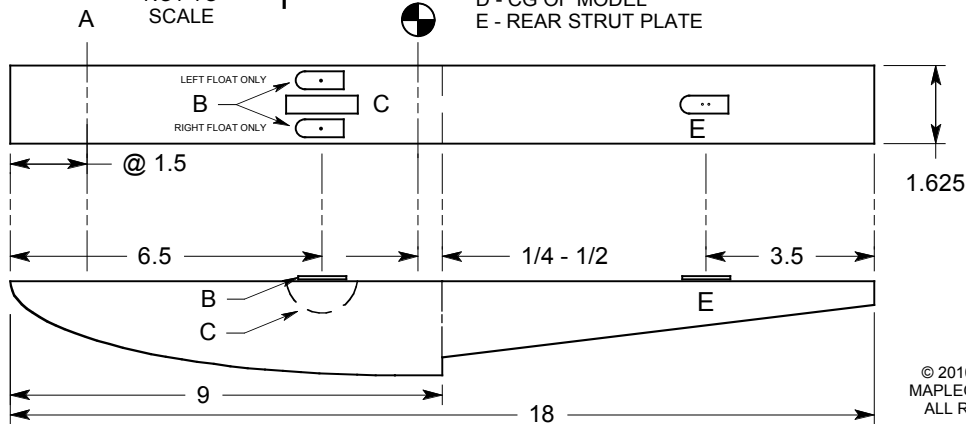

PARK FLYER FLOATS

DESIGNED BY THAYER SYME
FOR THE ELECTRIFLY FLYLITE FROM GREAT PLANES

PROTOTYPE FLOAT BLANKS WERE CUT IN TWO PIECES 1.625 INCHES WIDE AS SHOWN FROM 2-INCH FOAM INSULATION THEN JOINED WITH FOAM SAFE CA AT STEP. SKIN BOTTOM OF FLOATS WITH PACKING TAPE. MOUNT TO FUSELAGE WITH STEP 1/4 - 1/2 INCH BEHIND CG WITH FLOAT TOP AND FUSELAGE LEVEL. ALL DIMENSIONS IN INCHES.